

**CaseLight is Now DLC Listed!**

# ILT CaseLight

LED Refrigerated Case Lighting System

*Cost-effective replacement  
for fluorescent lights in  
convenience and grocery store  
refrigerated display cases.*

**ILT INNOVATIONS**

InternationalLight Technologies, Peabody, MA (USA) • 40 Years of Lighting Experience – We Know Light!

# ILT CaseLight™

## Refrigerated Display Case LED Lighting System

International Light Technologies (ILT), a US company with 40-plus years of lighting experience, manufactures CaseLight LED-based refrigerated display case lighting fixtures. CaseLight modules are designed to replace traditional fluorescent lighting fixtures in vertical refrigerated and freezer display cases in Convenience and Grocery Stores.

Convenience and Grocery store managers know they need to replace traditional fluorescent lighting in their refrigerated display cases with LED-based lighting modules. Why? Because of LED lighting's many advantages:

- ◆ Reduced energy consumption
- ◆ Extremely low maintenance
- ◆ Elimination of hazardous waste issues

But what company and what product can deliver a *total cost-effective LED lighting solution?*

### ILT and CaseLight!

*The Winning Combination for Convenience and Grocery Stores!*

## CaseLight Features Include:

- ◆ Fast ROI – 18-20 Months – Even faster with Rebates!
- ◆ Highest Color Rendering Index (CRI) Available – Reds are Red, Blues are Blue!
- ◆ Unparalleled Customer Support from Initial Inquiry through Final Installation
- ◆ Designed for Retrofitting Fluorescent Lights in Refrigerated Display Cases, Freezer Display Cases, Cooler Display Cases, Reach-in Display Cases, Vertical Display Cases, Heated Food Display Cases, etc.
- ◆ Even Light Distribution Throughout Display Case - LEDs Point Directly at Product
- ◆ No Exposed Lenses to Crack or Break - Durable Aluminum Extrusion Construction Protects LEDs
- ◆ 5 Year CaseLight Warranty
- ◆ All CaseLight Fixtures Manufactured in USA
- ◆ 40-Plus Years of Lighting Experience

## ROI – The Bottom Line in LED Retrofitting

Convenience and Grocery store managers know that replacing standard fluorescent lighting in refrigerated and freezer display cases with LED-based lighting is the RIGHT thing to do, but is it COST-EFFECTIVE? *In other words, what's the Return on Investment (ROI) for performing this retrofit?*

Let's look at the **major components** that go into a CaseLight ROI calculation:

## I. Energy Savings up to 80%

First, there's the energy savings gained by retrofitting with CaseLight. CaseLight operates on as little as 20 watts of energy per refrigerated display case door, reducing light energy consumption by up to 80% compared to standard fluorescent fixtures.



### Wattage to Drive Various Lighting Systems

(5-door case example - 60" units)

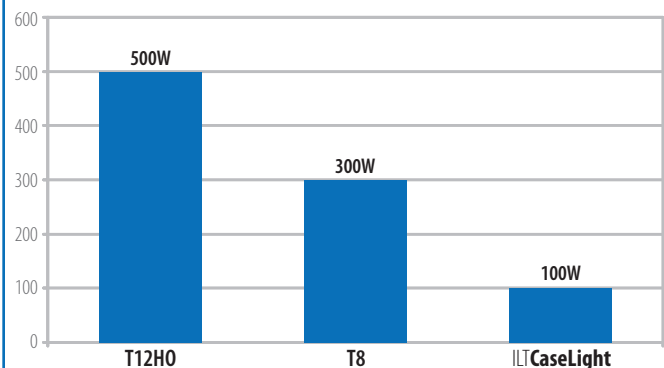

U.S. D.O.E. PNNL-18873

## II. Additional Energy Savings

And then there's the additional energy savings gained from a CaseLight retrofit. The major contributor is reduced compressor load due to the lower operating temperature of LED-based CaseLight fixtures compared to standard fluorescent display case lighting.

In terms of reduced load on the compressor, CaseLight saves 876 kWh compared to T12HO fluorescent lamps and 717 kWh compared to T8 fluorescent lamps.

## III. Lower Maintenance Costs

Reduction of maintenance costs is yet another benefit to retrofitting with CaseLight LED fixtures.

Examples include:

- ◆ 50,000 hour LED life vs. 16,000 hour fluorescent life (See chart)
- ◆ No lamp replacement for 6-10 YEARS!
- ◆ Reduced maintenance of ballasts, lenses and sockets
- ◆ No exposed lenses to crack or break
- ◆ Durable aluminum extrusion construction protects LEDs

Also included in lowered maintenance costs is the reduction in disposal costs. Fluorescent lamps contain mercury and are considered "hazardous waste" by the EPA. CaseLight LED fixtures do NOT contain mercury and are RoHS compliant.

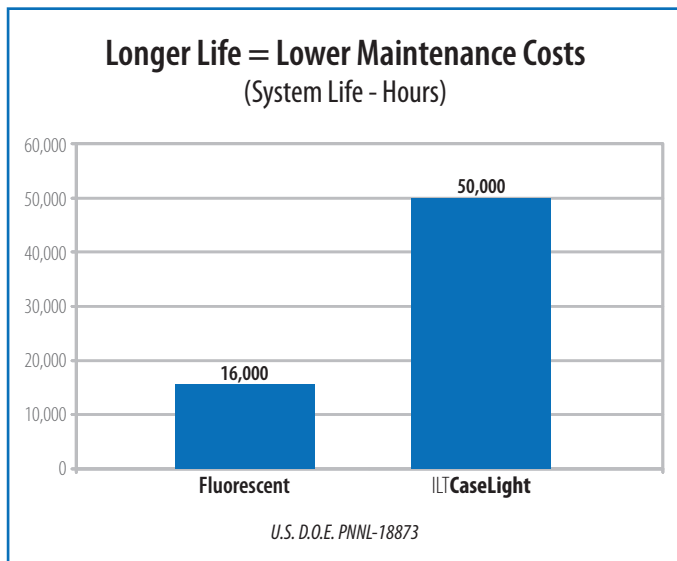

## IV. Utility and Government Rebates

Utility company and government rebates can be key ROI components that make the retrofit project very cost-effective. But collecting and understanding all of this rebate info and applying it to the ROI calculation can be frustrating and time-consuming for Convenience and Grocery store management.

That's why International Light Technologies will perform a detailed ROI calculation before the first location is retrofitted with CaseLight LED fixtures, including researching and supplying specific utility and government rebates available in your geographic area.

One last point about energy rebates – they are in place today, but may not be in the future. Waiting to perform a CaseLight LED fixture retrofit could mean that you miss your rebate opportunity.

One Massachusetts-based wholesale club was able to reduce their ROI from 2+ years to less than 18 months by participating in the Mass Save rebate program sponsored by regional utilities.

## The Bottom Line – A Fast ROI

In many instances a very attractive return on investment (ROI) of 18-20 MONTHS is attainable!

Regions of the country with high utility rates and/or aggressive rebate programs can enable retailers to reduce the **ROI for a CaseLight retrofit to less than one year!**

## Additional CaseLight Benefits

A CaseLight retrofit includes these additional benefits:

- ◆ Merchandise is presented in a more visually appealing manner using CaseLight LED fixtures
- ◆ Highest Color Rendering Index (CRI) available\* – reds are red, blues are blue
- ◆ CaseLight optics put the light where it will do the most good – on the products!

\* Color Rendering Index (CRI) – The ability of a light source to make an object appear its true color.

## We're Here to Help with UNPARALLELED CUSTOMER SUPPORT

International Light Technologies understands that LED-based refrigerated display case lighting is a new technology for many Convenience And Grocery Store Managers. That is why we provide UNPARALLELED CUSTOMER SUPPORT on ALL CaseLight LED lighting system inquiries, from initial conversation through final installation.

NEXT STEP: If learning more about LED display case lighting is high on your "to do" list, please give Phil Goodwin, ILT CaseLight Sales Manager, a call today at 978-818-6180 X128 or email Phil at pgoodwin@intl-lighttech.com.

Part Number	Description	Color Temp. (K)	Lumens	Energy (Watts)	Life (Hrs)	CRI (Typical)
ILT48-BAO-W50CE	CaseLight, 48", Brite Anodize, Center unit	5000	825	17	50000	87
ILT48-BAO-W50LE	CaseLight, 48", Brite Anodize, Left unit	5000	412	9	50000	87
ILT48-BAO-W50RE	CaseLight, 48", Brite Anodize, Right unit	5000	412	9	50000	87
ILT48-BAO-W40CE	CaseLight, 48", Brite Anodize, Center unit	4000	750	17	50000	88
ILT48-BAO-W40LE	CaseLight, 48", Brite Anodize, Left unit	4000	375	9	50000	88
ILT48-BAO-W40RE	CaseLight, 48", Brite Anodize, Right unit	4000	375	9	50000	88
ILT48-BAO-W35CE	CaseLight, 48", Brite Anodize, Center unit	3500	750	17	50000	88
ILT48-BAO-W35LE	CaseLight, 48", Brite Anodize, Left unit	3500	375	9	50000	88
ILT48-BAO-W35RE	CaseLight, 48", Brite Anodize, Right unit	3500	375	9	50000	88
ILT60-BAO-W50CE	CaseLight, 60", Brite Anodize, Center unit	5000	1100	23	50000	87
ILT60-BAO-W50LE	CaseLight, 60", Brite Anodize, Left unit	5000	550	12	50000	87
ILT60-BAO-W50RE	CaseLight, 60", Brite Anodize, Right unit	5000	550	12	50000	87
ILT60-BAO-W40CE	CaseLight, 60", Brite Anodize, Center unit	4000	1000	23	50000	88
ILT60-BAO-W40LE	CaseLight, 60", Brite Anodize, Left unit	4000	500	12	50000	88
ILT60-BAO-W40RE	CaseLight, 60", Brite Anodize, Right unit	4000	500	12	50000	88
ILT60-BAO-W35CE	CaseLight, 60", Brite Anodize, Center unit	3500	1000	23	50000	88
ILT60-BAO-W35LE	CaseLight, 60", Brite Anodize, Left unit	3500	500	12	50000	88
ILT60-BAO-W35RE	CaseLight, 60", Brite Anodize, Right unit	3500	500	12	50000	88
ILT70-BAO-W50CE	CaseLight, 70", Brite Anodize, Center unit	5000	1280	27	50000	87
ILT70-BAO-W50LE	CaseLight, 70", Brite Anodize, Left unit	5000	640	14	50000	87
ILT70-BAO-W50RE	CaseLight, 70", Brite Anodize, Right unit	5000	640	14	50000	87
ILT70-BAO-W40CE	CaseLight, 70", Brite Anodize, Center unit	4000	1175	27	50000	88
ILT70-BAO-W40LE	CaseLight, 70", Brite Anodize, Left unit	4000	587	14	50000	88
ILT70-BAO-W40RE	CaseLight, 70", Brite Anodize, Right unit	4000	587	14	50000	88
ILT70-BAO-W35CE	CaseLight, 70", Brite Anodize, Center unit	3500	1175	27	50000	88
ILT70-BAO-W35LE	CaseLight, 70", Brite Anodize, Left unit	3500	587	14	50000	88
ILT70-BAO-W35RE	CaseLight, 70", Brite Anodize, Right unit	3500	587	14	50000	88

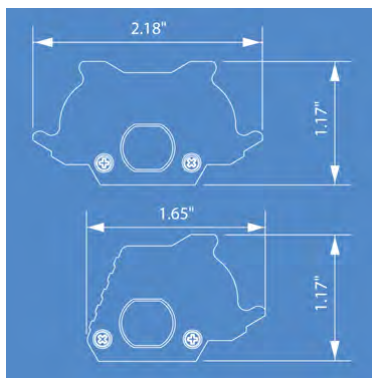

**InternationalLight**  
TECHNOLOGIES

ISO 9001:2008

10 Technology Drive, Peabody, MA 01960  
978-818-6180 978-818-6181 fax  
intl-lighttech.com

