

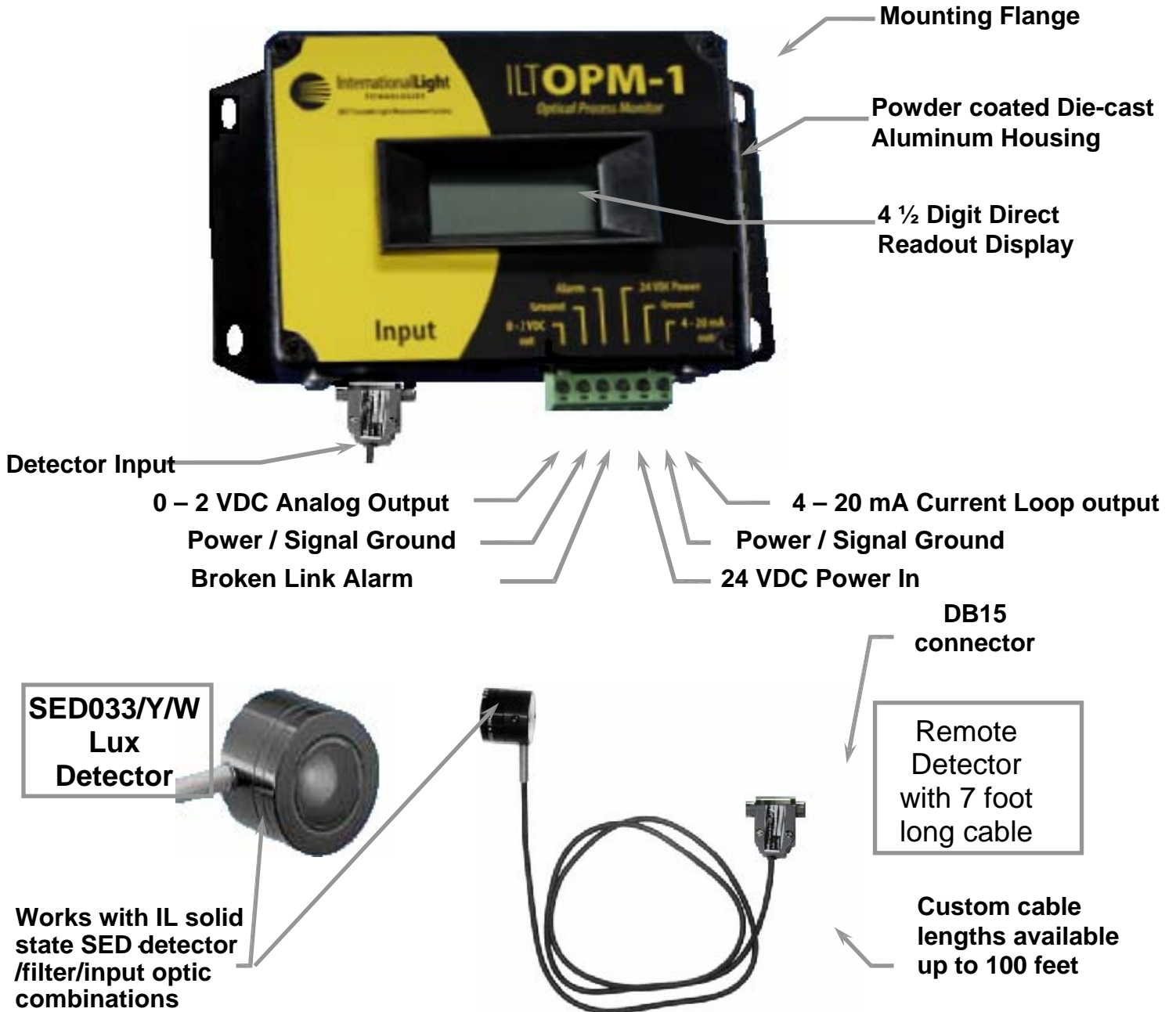

OPERATION MANUAL



The ILTOPM Series optical process monitors are designed for on-line monitoring of optical intensities in real-time applications. The remote detector version is configured to accept most of the standard receptor / filter combinations in the IL line. The sender has a built-in read-out as well as the electrical interface for 4-20 mA operation. The detector cable interfaces with the sender through a 15-pin D-sub connector.

TYPICAL SYSTEM CONNECTION

A basic system configuration using the ILTOPM-1 is shown in Figure 1. The optical source associated with the process is monitored by the remote optical pickup. Light from the optical pickup is conducted by the electrical cable to the sender unit, which is powered by an external 24 VDC supply. The sender readout provides a local indication of process condition and verifies proper optical alignment. A third wire connects the current output of the sender to the customer receiver, typically a Programmable Logic Controller (PLC) which interacts with the monitored process in response to the signal readout.



Figure 1.

ALARM OUTPUT

The ILTOPM-1 provides an indication of either a broken link or an input overdrive condition. The output is in the form of an open-collector transistor as shown in Figures 2 and 3. Figure 2 shows a connection to a standard TTL gate for interface to external logic. A 20 K pull-up resistor connected to the +5VDC logic supply provides source current for the TTL gate.

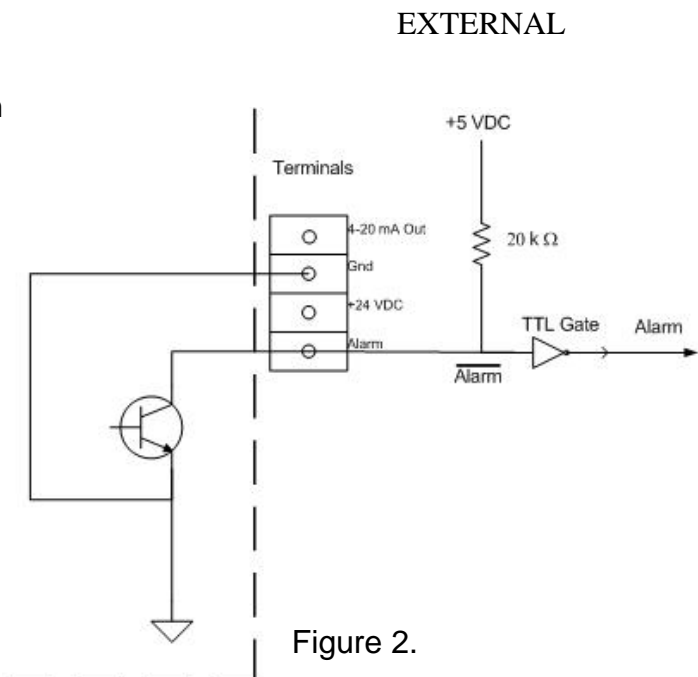

Figure 2.

A visual indication of a broken link can be provided by connecting an LED directly to the Alarm output as shown in Figure 3. Instead of a 5 VDC supply, the +24 VDC supply could be used with an appropriately chosen current limiting resistor.

0 – 2 VDC ANALOG OUTPUT

A voltage output proportional to the input signal is available at the leftmost 2 pins on the external connector, as show in Figure 4. Early production models may indicate No Connection (NC) at these pins, but the signal is provided nevertheless. The drive is a low-impedance op-amp output capable of supplying up to 2mA.

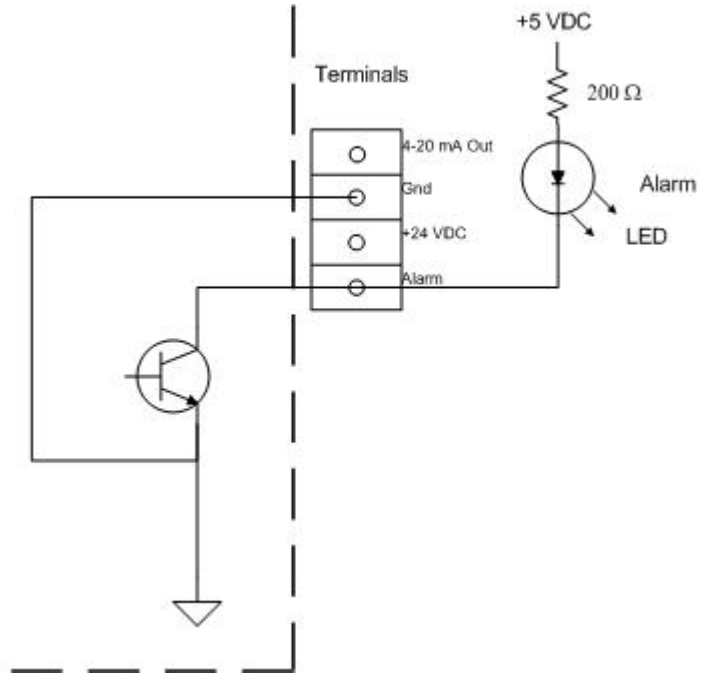

Figure 3.

Analog Output Ground
(Common to current
signal) ground)

0 – 2 VDC Analog
Output

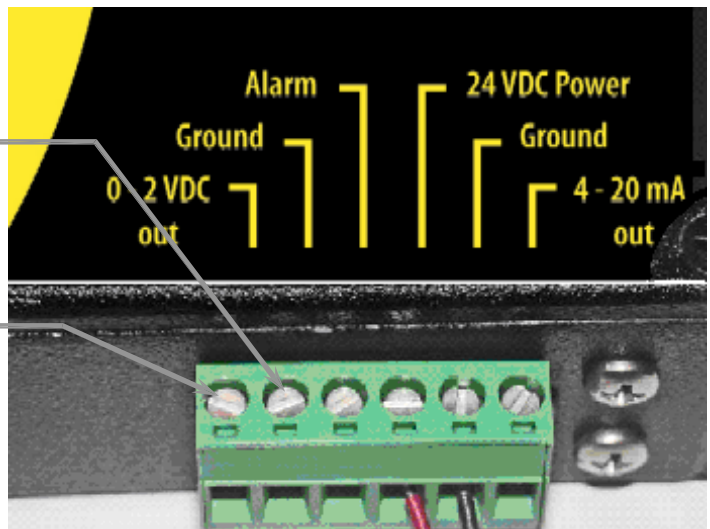
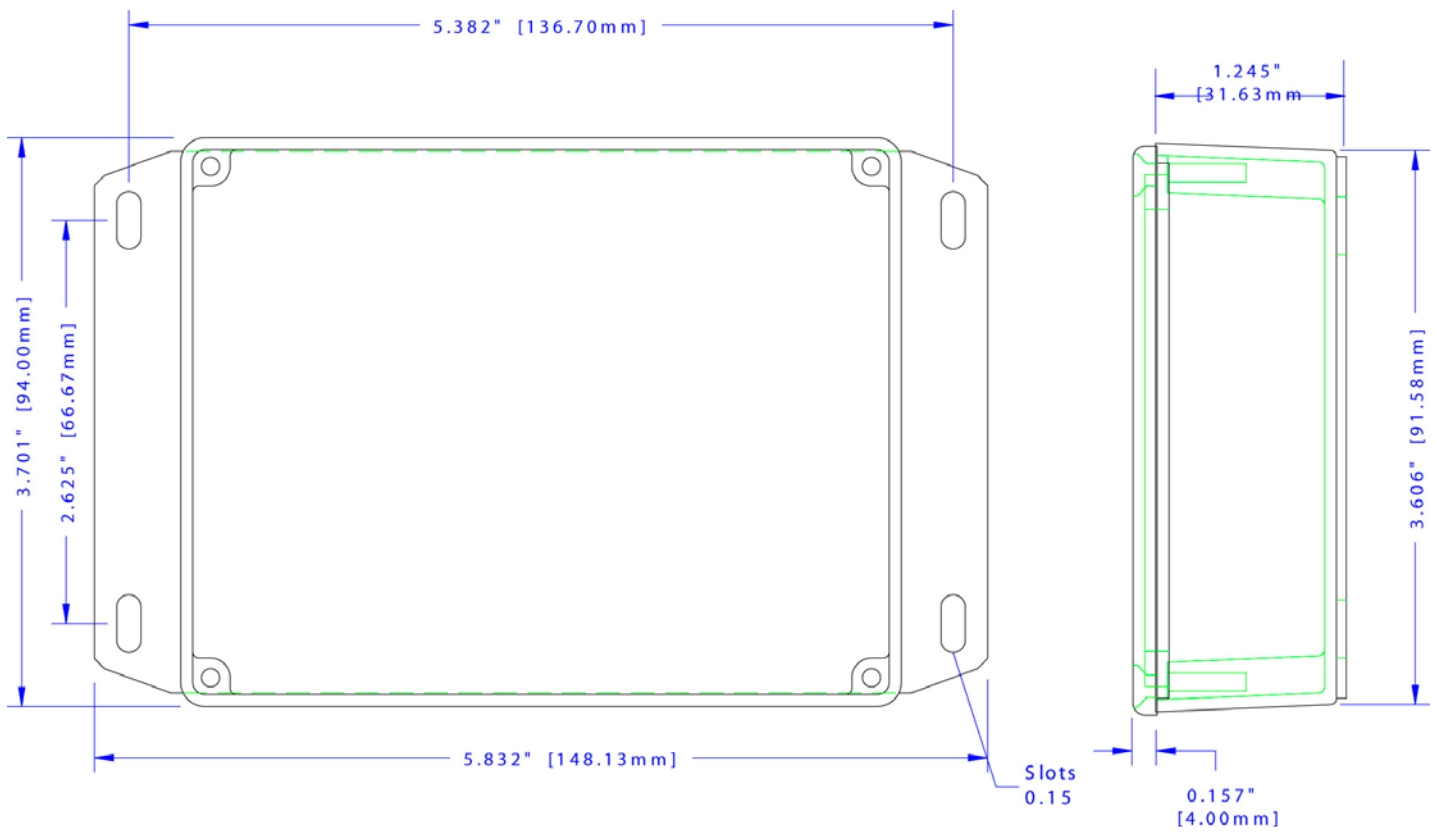

Figure 4.

Specifications for detector version

- 4 ½ Digit direct readout, calibrated in customer selected units
- NIST Traceable
- Linearity better than 0.05%
- Output response bandwidth < 1 sec single pole RC time constant (can be modified at customer request)
- 4 – 20 mA current loop output interfaces to standard programmable logic controllers (PLC's). Overload protected at 38 mA. Can drive conductive and capacitive loads.
- Alarm output indicates broken link condition. Open collector output with characteristics:
 - Maximum switched voltage – 36 VDC
 - Maximum on current – 20 mA
 - On condition saturation voltage - 0.35 VDC
 - Off condition leakage current - $\pm 1 \mu A$
- 0 – 2 VDC analog voltage output, short circuit protected, 2 mA drive capability.
- 24 VDC operation (18 – 28 VDC), 40 mA maximum supply current under 20 mA output condition. Protected against over-voltage, supply reversal and line transients.
- Operating temperatures:
 - Detector: 0- 40 Degrees C
 - OPM1: 0-70 Degrees C
- Rugged die-cast aluminum housing with black powder coat finish
- Weight: 0.75 lb (0.34 Kg)
- Dimensions: 3.70" (94.0 mm) W x 5.38" (137 mm)L x 1.40" (35.7 mm)H

Component Physical Dimensions



InternationalLight
TECHNOLOGIES

10 Technology Drive, Peabody, MA 01960
978-818-6180
www.intl-lighttech.com