

# "Light Edge" Summit Series ILT-1X1-W65-025



**ILT INNOVATIONS**

Products • Capabilities • Applications

**InternationalLight**  
TECHNOLOGIES

The "Light Edge" Summit Series is designed for 3" to 6" double faced Sign Cabinet. The integrated 10 x 45 degree optical lens transforms the light into a focused "Light Edge". This allows the module to be placed on the perimeter of the cabinet up to 48" in wide.

## Applications:

- Shallow Sign Cabinets up to 3"-6" deep.
- Sign cabinet Retrofit.

## Features:

- 1, 2 Watt 3030 SMD LED per module.
- 10 x 45 Degree integrated optic lens.
- Exposed aluminum PCB board.
- 3M Heat Tranfer double faced tape plus Mechanical Fasteners.
- Lumen out-put for 160-170 lm per module
- 20 Module per strip, 30 modules on a 12 volt 60 watt power supply.
- 20 Module max run, Load needs to be balanced.
- IP65 Rated.



ILT-1X1-W65-025

## Specifications:

"Light Edge" Summit Series Part#	Operating Voltage (V)	Power Dissipation (W)	Peak Wavelength (nm)	Beam Angle	Luminous Flux/Module (lm/pc)	Luminous Flux/Module (lm/pc)	Modules/Foot	LED Quantity (pc/module)	Qty on 60W power supply (20 pc/run max)	Module Dimensions (LxWxH)
ILT-1X1-W65-025	12	2	6500k	10 X 45	160 (min)	170 (max)	2	1	30 or 15 ft	2.05"x.1.18"x0.56"

## Mechanicals:

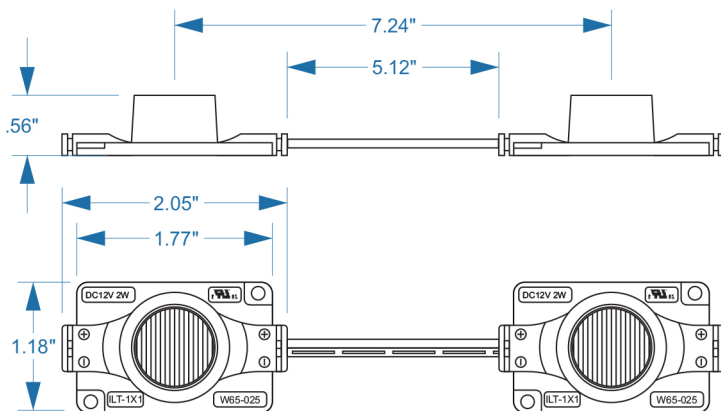

## Lens Optics:

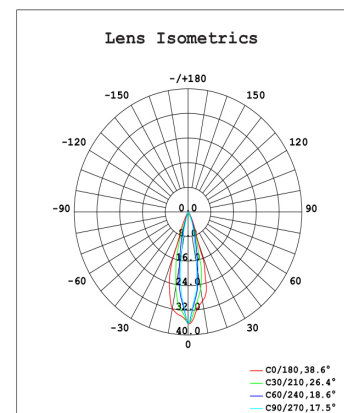

ILT-1X1-W65-025  
Mounted to the perimeter of a 6" deep double faced cabinet



**InternationalLight**  
TECHNOLOGIES

For additional information call: Joe Reis at 978-818-6180 ext 214  
For a Quote and Population layout,  
send PDF, drawings to: Tabitha at [tleverone@intl-lighttech.com](mailto:tleverone@intl-lighttech.com)  
10 Technology Drive, Peabody, MA 01960  
phone: 978-818-6180 fax: 978-818-6181  
web: [www.intl-lighttech.com](http://www.intl-lighttech.com)